

## ELECTRIC HALF SIZE CONVECTION OVENS



**Model COC-E1**  
Shown with left hand hinge & right side controls

### Standard Features

Half-size electric, forced air, single and double stack convection type oven. Standard specifications include 9.5 KW per cavity and a patented two speed fan-within-a-fan enhanced air flow system powered by an energy efficient 1/4 HP two-speed fan motor

Door interlock switch automatically turns the fan and heating elements off when the door is open. A manual rotary switch will turn the fan on when the door is open for quick cool-down. The 60-minute time has a continuous ring with manual shut-off. An indicator light glows when the heating elements are on.

The oven interior measures 23" wide (584mm) by 20" high (508mm) by 15 5/8" deep (397mm). The cooking chamber is porcelain enamel over heavy gauge steel with removable 11-position rack guides with 1 5/8" spacing (41mm) and 5 heavy-duty adjustable chrome-plated racks.

The oven exterior measures 31" wide (787mm) by 27 1/2" deep (699mm) by 25" (635mm). Front, top, sides and trim are constructed with stainless steel.

A single fully insulated stainless steel door with thermal pane window opens a full 180° and features a unique 23" opening wide mouth design for easy viewing and sideways loading of 1/2 - size sheet pans.

Ovens may be ordered with left hand hinge and right side controls or right hand hinge and left hand controls.

### Models

- COC-E1
- COC-E2

### Design Features

- Energy efficient 9.5 KW per oven direct forced air heat system
- 208V or 220V-240V, 60hz or 50hz 1 or 3 phase
- Electronic temperature control
- Double-pane thermal glass door windows
- Interior oven light
- 60-minute continuous ring timer with manual shut-off
- 150°F (65°C) to 550°F (288°C) temperature range
- 1/4 HP air-cooled two-speed fan motor
- Cool down fan mode
- Elements-on and temperature-ready indicator lights
- Porcelain enamel oven interior
- 11-Position removable rack guide with 1 5/8" spacing
- 5 Heavy-duty, positive-stop, chrome-plated wire racks
- Stainless steel front, top and sides
- Stainless steel, fully insulated hinged door
- Front mounted control panel for easy service access
- 1/8" Welded angel iron frame construction
- Heavy-duty industrial grade insulation in top, sides, back and doors
- Limited 1-year parts, labor and door warranty

### Options & Accessories

- Stainless steel stand with or without casters
- Additional oven racks
- International voltages, 50hz
- Solid door
- Stacking kit
- Left hand hinge, Right hand controls
- Right hand hinge, Left hand controls

### Certifications





## ELECTRIC HALF SIZE CONVECTION OVENS

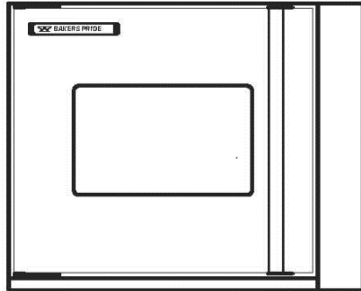

Front View

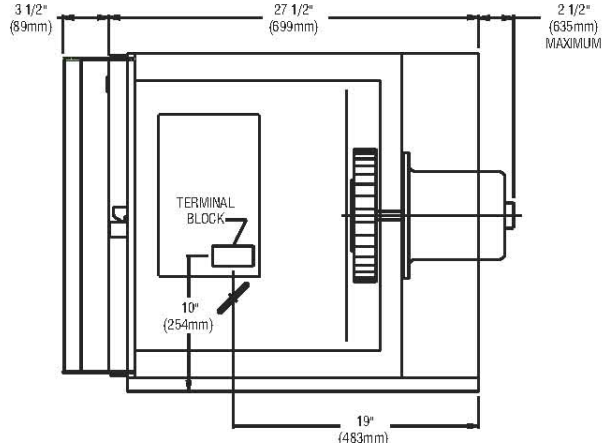

Side View – Single Unit

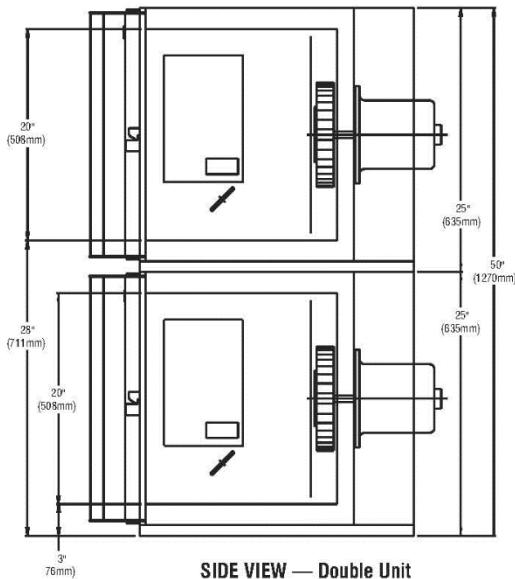

SIDE VIEW — Double Unit

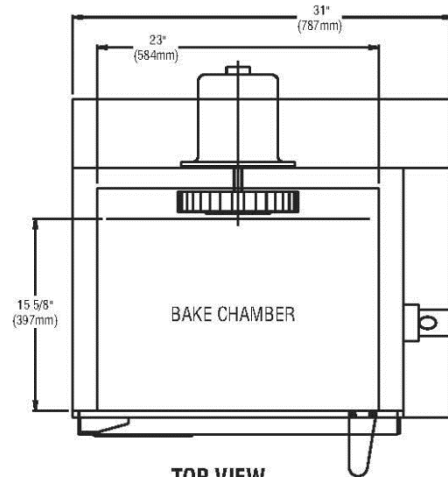

TOP VIEW

ALL DIMENSIONS NOMINAL

SHIPPING INFORMATION										
Model	SHIPPING WEIGHT		CARTON DIMENSIONS						Crate size	
	Lbs	Kilos	Width		Depth		Height		Cubic Feet	Cubic Meter
			In	mm	In	mm	In	mm		
COC-E1	300	136	35.5	902	34.5	877	29	737	20.6	.6
COC-E2	Shipped in two cartons as per above specifications									

	MINIMUM CLEARANCES			
	Vent Hood		Direct Venting	
	Inches	mm	Inches	Mm
Left Side	1	25	NA	NA
Right Side	1	25	NA	NA
Rear	1	25	NA	NA

POWER SUPPLY										
Model	Watts	Voltage	Phase	Amps			Fan 50HZ		Fan 60HZ	
				L1	L2	L3	RPM-low	RPM-high	RPM-low	RPM-high
COC-E1	9.5	208	3	29	29	25	825	1425	1140	1725
COC-E1	9.5	220/240	3	27.6	27.6	23.6	825	1425	1140	1725
COC-E1	9.5	208	1	47.3	47.3		825	1425	1140	1725
COC-E1	9.5	220/240	1	44.8	44.8		825	1425	1140	1725

Continuous product improvement is a policy of Bakers Pride Oven Company. Therefore, specifications and design are subject to change with notification.