

PICL Series Pizza Prep Table

REFRIGERATION
AVANTCO

www.AvantcoRefrigeration.com

MODEL #178PICL1HC

PICL SERIES - PIZZA PREP TABLE

Ample prep space to create pizzas, subs, and calzones with convenient cold ingredient storage.

CABINET CONSTRUCTION

Heavy duty construction includes strong 430 type stainless steel exterior and 304 type stainless steel interior. Overall working height is 35¼".

Foamed-in-place CFC- and HCFC-free polyurethane insulation enhances the structural integrity of the cabinet and helps increase energy efficiency. Insulated lid helps maintain safe product temperatures.

Full-length, 19 $\frac{7}{16}$ " deep cutting board for easy prep work.

Doors feature easy-to-use, recessed handles for quick interior access. Doors stay open past 90° for easy loading, but will self-close under 90° to save energy.

REFRIGERATION SYSTEM

Environmentally safe R290 refrigerant. Rear-mounted condensing unit positioned for easy maintenance.

SHELVING

1 white epoxy-coated steel shelf included. It accommodates up to 90 lb. and adjusts to best suit your needs.

MODEL FEATURES

Intuitive, easy to read digital controls. Auto-defrost function simplifies maintenance and servicing.

Top pan rail holds up to (6) ½ size, 6" deep food pans. Pan rail is air cooled from the bottom. Pan dividers included.

SPECIAL FEATURES

- Accommodates up to (6) ½ size, 6" deep food pans
- Insulated lid covers pan rail to maintain proper temperatures
- 19 $\frac{7}{16}$ " deep, full length cutting board
- 1 interior epoxy-coated shelf holds up to 90 lb. of weight
- Digital temperature controls hold at 33-40°F
- Foamed-in-place polyurethane insulation
- Environmentally-friendly R290 refrigerant
- 430 type stainless steel exterior; 304 type stainless steel interior
- Auto defrost feature
- ½ hp compressor



WARRANTY

RESIDENTIAL: Avantco assumes no liability for parts or labor coverage for component failure, factory defect or any other damages for units installed in non-commercial foodservice or residential applications.



Parts & Labor



Compressor



PICL Series Pizza Prep Table

MODELS #178PICL1HC



www.AvantcoRefrigeration.com

TECHNICAL DATA

Dimensions

Exterior Dimensions	49 ⁷ / ₈ "W x 36 ⁷ / ₈ "D x 42 ⁷ / ₈ "H
Interior Dimensions	27 ¹ / ₂ "W x 27"D x 23"H
Working Height	35 ¹ / ₄ "
Overall Height (Lid Open)	57"
Cutting Board Dimensions	49 ³ / ₄ "W x 19 ¹ / ₁₆ "D x ³ / ₄ "H
Net Volume	9 cu. ft.
Net Weight	308 lb.
Gross Weight	363 lb.
Pan Capacity (6" Deep)	(6) ¹ / ₃
Packing Dimensions	55"W x 36 ¹ / ₂ "D x 45 ³ / ₄ "H

Cooling

Temperature Range	33°F - 40°F
Refrigerant	R290
Max. Ambient Temperature	90°F
Defrosting	Automatic
Temperature Controller	Digital
Horsepower	1/6

Construction

Exterior Material	Type 430 Stainless Steel
Interior Material	Type 304 Stainless Steel
Insulation Material	Foamed-in-place Polyurethane
Shelves	(1) 26 ³ / ₄ "W x 24 ¹ / ₁₆ "D
Shelf Material	Epoxy-coated Steel
Shelf Load Capacity	90 lb.

Electrical

Voltage	115
Amps	2.6
Hz	60
Phase	1
Plug Type	NEMA 5-15P
Electrical Cord Length	84"

PLAN VIEW

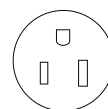
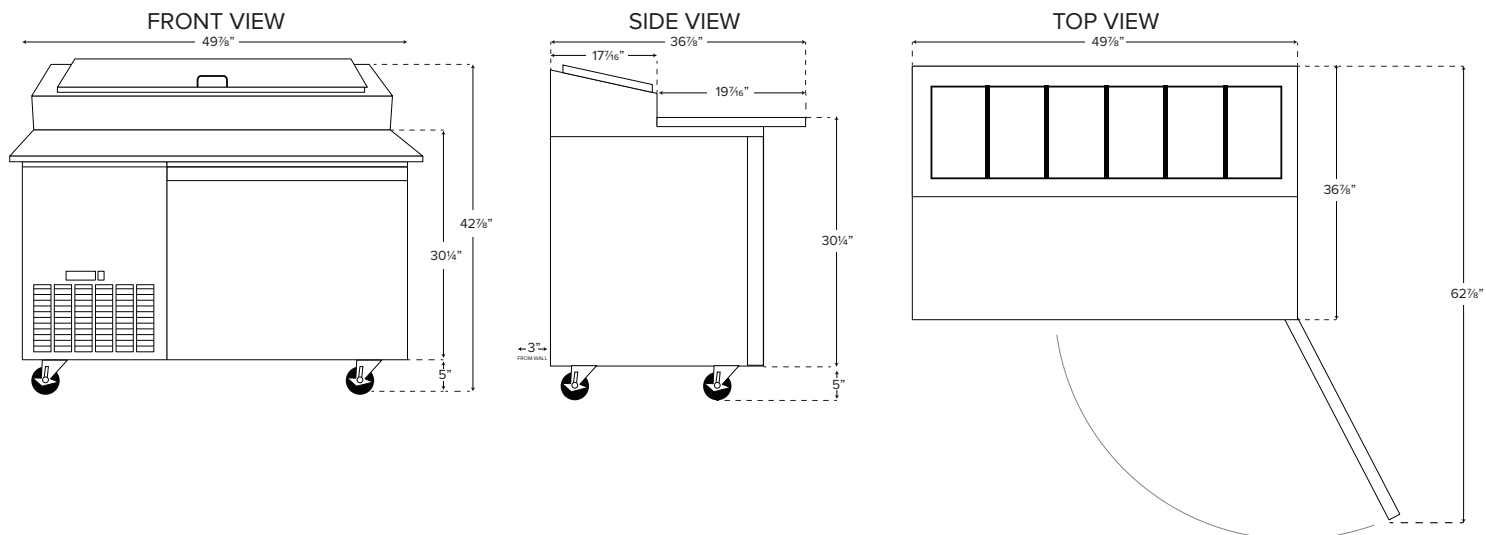

NEMA 5-15P